



User Manual

Spend a little Live a lot.



Bluetooth® GPS Watch with Heart Rate Measurement



Product
Info



www.aldi.co.uk

+ VIDEO

QR codes take you where you want to go quickly and easily

Whether you require **product information**, **spare parts** or **accessories**, details on **warranties** or **aftersales services**, or if you want to watch a **product demonstration video**, our QR codes will take you there in no time at all.

What is a QR code?

A QR code (QR = Quick Response) is a type of matrix that can be read with a smartphone camera and that contains a link to a website or contact details, for example.

Advantage: You do not need to manually enter a website address or contact details.

This is how it works

To scan the QR code, all you need is a smartphone with QR code reader software and an internet connection*. This type of software can be downloaded for free from your app store.

Try it out now

Just scan the QR code with your smartphone and find out more about the Aldi product you have purchased.*

Your Aldi Service Portal

All details mentioned above can also be found in the Aldi Service Portal at www.aldi.co.uk.



* Depending on your tariff plan you may be charged for the connection.

Contents

Overview	4
Use.....	5
Product contents/device parts	6
General information	7
Reading and storing the instruction manual	7
Explanation of symbols	7
Checking the GPS watch and product contents	9
Safety.....	9
Proper use.....	9
Safety notes.....	10
Water-resistance.....	16
Start-up	18
Charging the battery pack of the GPS watch	18
Chest strap.....	20
Bike holder.....	22
Downloading and installing the Crane Connect app	23
General information about GPS.....	24
Operation	27
Turning the GPS watch on and off	27
Locking keys	27
Illumination of the display panel.....	28
GPS watch modes	29
System setting mode	30
Time mode	37
Workout mode with GPS.....	37
Interval mode with GPS.....	42
History mode.....	45
Alarm mode	48
Data transfer.....	49
Cleaning and maintenance	50
Changing the transmitter unit's battery.....	51
Storage	53
Troubleshooting	54
Technical data	58
Declaration of conformity	59
Disposal	59
Disposing of the packaging.....	59
Disposing of old devices.....	60
Warranty.....	61
Warranty Card	61
Warranty conditions.....	62

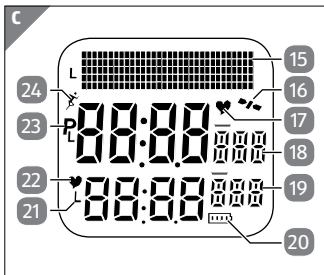
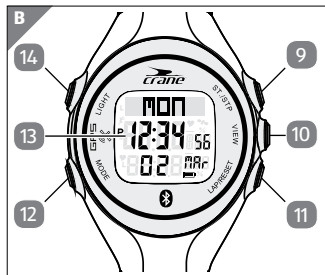
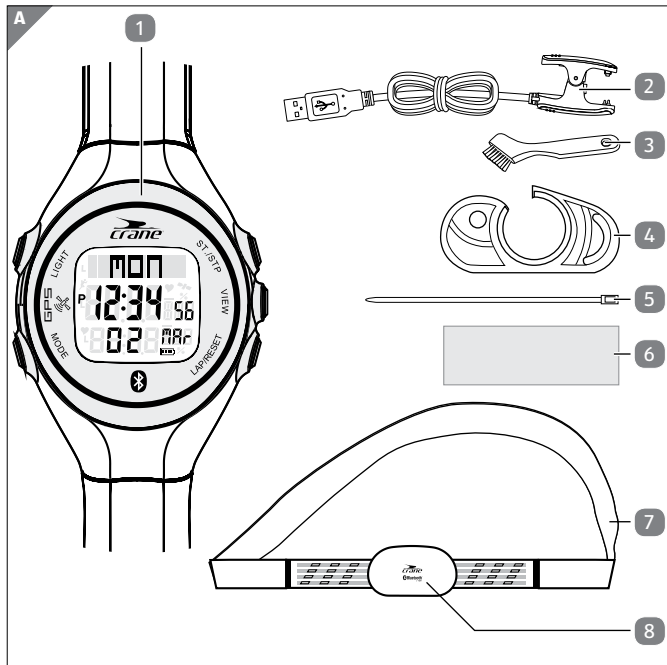

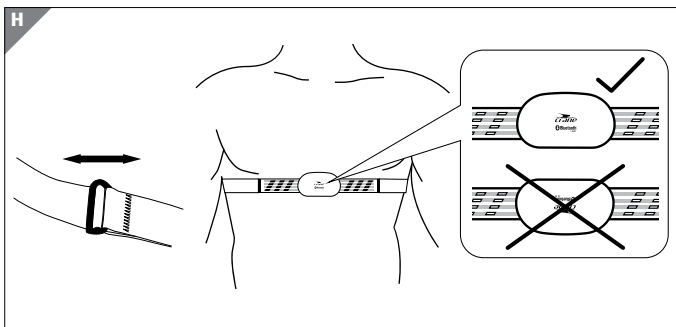
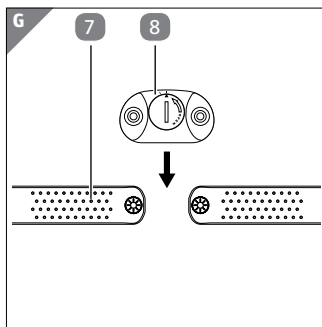
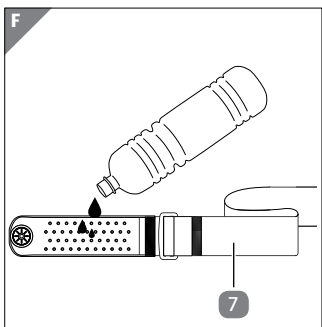
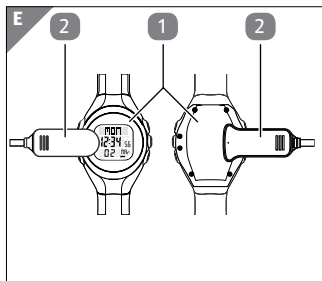
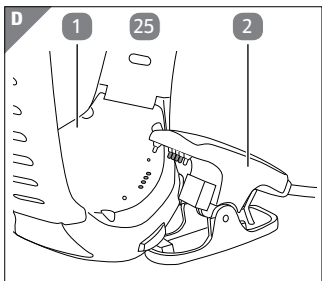

Product contents/device parts

- 1 GPS watch
- 2 USB connector cable
- 3 Cleaning brush
- 4 Bike holder
- 5 Cable strap for **4**
- 6 Fixing plate for **4**
- 7 Chest strap
- 8 Transmitter unit
- 9 ST./STP key (start/stop)
- 10 VIEW key
- 11 LAP/RESET key
- 12 MODE key
- 13 Display panel
- 14 LIGHT key (light)
- 15 Top row
- 16 GPS icon
- 17 Heart rate icon
- 18 Centre row
- 19 Bottom row
- 20 Battery charging level icon
- 21 L icon (lap)
- 22 Heart rate icon
- 23 P icon (12 h time format)
- 24 Workout icon
- 25 Charging contacts

General information

Reading and storing the instruction manual



This instruction manual accompanies this Bluetooth® GPS “Watch with Heart Rate Measurement”. It contains important information on start-up and handling.

For improved readability, the Bluetooth® GPS watch with heart rate measurement will be referred to below merely as the “GPS watch” below.

Before using the GPS watch, please read through the instruction manual carefully. This particularly applies for the safety notes. Failure to comply with the instruction manual may result in damage to the GPS watch and falsified workout results.

The instruction manual is based on the standards and rules in force in the European Union. When abroad, you must also observe country-specific guidelines and laws.

Store the instruction manual and packaging for future use. If you pass the GPS watch on to third parties, please be absolutely sure to include this instruction manual.

Explanation of symbols

The following symbols and signal words are used in this instruction manual, on the GPS watch or on the packaging.

⚠ WARNING!

WARNING! This signal word designates a hazard with moderate degree of risk which may lead to death or severe injury if not avoided.

⚠ CAUTION!

CAUTION! This signal word designates a hazard with low risk that, if not avoided, may result in minor or moderate injury.

NOTICE!

NOTICE! This signal word warns against potential damages to property.



This symbol provides you with useful supplementary information on assembly or operation.



Declaration of conformity (see chapter “Declaration of conformity”): Products marked with this symbol fulfil the requirements of the EC directives.



DANGER if swallowed

WARNING! This signal warns of the risk of swallowing and choking.

Checking the GPS watch and product contents

1. Carefully take the GPS watch and its accessories out of the packaging.
2. Remove the packaging material and all protective wrapping.
3. Check to make sure that the delivery is complete (see **fig. A**).
4. Check whether the GPS watch or the individual parts exhibit damages. If this is the case, do not use the GPS watch. Contact the manufacturer via the service address indicated on the warranty card.

Safety

Proper use

The GPS watch has a navigation system. The US “GPS” satellite network orbiting the earth can be used to determine the position of the user. This can be done any time and anywhere in the world when outdoors.

The GPS watch primarily serves to measure distance, speed and altitude and is particularly suitable for sports like running, cycling, hiking, sailing, skiing etc.

However, the GPS watch is not suitable for demanding applications such as paragliding, skydiving or gliding.

The GPS watch is designed for private use and is not suitable for commercial use.

The GPS watch can also be used as a workout aid for measuring and displaying your heart rate. The GPS watch is not a medical device.

Only use the GPS watch as described in this instruction manual. Any other use is considered improper and may result in damage to property.

The manufacturer or vendor accepts no liability for damage caused by improper or incorrect use.

Safety notes

WARNING!



DANGER if swallowed

Risk of swallowing and choking!

Keep batteries out of reach of children and animals. Swallowing may lead to serious injury or death in as little as two hours due to internal burns.

- If swallowed, go straight to a hospital emergency room.
- Dispose of used batteries immediately.
- Keep the GPS watch and coin sized batteries out of sight and reach of children and animals.
- If you suspect a child has swallowed a button battery, immediately go to a

hospital emergency room. Do not let the child eat or drink and do not induce vomiting

Emergency Telephone Number: 999 and the National Poisons Information Service: 111 (UK)/01 809 2166 (Ireland).

⚠ WARNING!

Risk of accident/injury!

Do not use the GPS watch when you are driving a vehicle. Looking away from the road is dangerous and may cause an accident; you or other persons could be injured as a result.

- Stop or let a passenger perform the settings.

⚠ WARNING!

Health hazard!

The GPS watch is not a medical device; it is a workout aid for measuring and displaying your heart rate.

- Always consult a physician before you start a regular workout routine.

- Persons with pacemakers may only use devices for measuring heart rate in consultation with their physician.
- Do not use the chest strap if you are allergic to latex. The chest strap may contain latex constituents and cause irritation and reddening of your skin.
- Batteries may pose a risk to health if ingested. You should therefore store the battery and the chest strap so that they are not accessible for small children. If a battery has been swallowed, you must seek immediate medical attention.
- Promptly remove an empty battery from the chest strap. Otherwise it could leak. In this case, avoid contact with skin, eyes or mucus membranes. In the event of contact with battery acid, immediately flush the applicable areas with plenty of clean water and consult a physician promptly.

⚠ WARNING!

Danger for children and persons with impaired physical, sensory or mental capacities (e.g. partially disabled persons, older persons with reduced physical and mental capacities) or lack of experience and knowledge (e.g. older children).

- The GPS watch may be used by children ages eight and over as well as persons with impaired physical, sensory or mental capacities or those lacking experience and knowledge if they are supervised or have been instructed in how to safely use the GPS watch and have understood the risks associated with using it.
- Children may not play with the GPS watch. Cleaning and user maintenance must not be performed by unsupervised children.
- Keep children under the age of eight away from the GPS watch and the accessories.
- Do not allow children to play with the packaging wrapper. They could swallow it and suffocate.

⚠ WARNING!**Risk of explosion and fire!**

Lithium battery packs and batteries could explode if handled improperly.

- Your GPS watch is operated with a lithium polymer battery pack, which you cannot replace.
- You may not heat, open or short circuit battery packs and batteries or dispose of them in fire.
- Do not drill through the GPS watch.
- To avoid overheating the battery pack, do not expose the GPS watch to direct sunlight or other heat sources, e.g. in a vehicle.
- Only use the enclosed charging cable and a USB port on your PC or a USB charger to charge the battery pack in the GPS watch.
- Never charge the battery pack at temperatures below +10 °C! This will damage the chemical composition of the cell and may result in a fire.
- Only replace the battery for the chest strap transmitter unit with an equivalent battery type (CR2032).

- Do not attempt to charge the battery or reactivate it with other means.

NOTICE!

Risk of damage!

Improper handling of the GPS watch may damage the GPS watch.

- Do not place any objects on the GPS watch and do not apply pressure to the display panel. Otherwise the display panel could break.
- Avoid contact between the display panel and angular objects.
- Avoid very strong magnetic fields (e.g. transformers). Otherwise, they could cause inconsistencies in measuring time and positioning. Failure to observe these notes may result in faults or damage to your GPS watch.
- For optimal battery pack power, avoid deep discharges. Charge the battery pack when only one bar is visible on the battery pack indicator.
- Do not overcharge the battery pack. Connecting a charged or partially

charged battery pack several times may overcharge it and damage the cells.

- Do not leave the battery pack connected to the charger for several days.
- **Never open the housing of the GPS watch or chest strap**, it does not contain any parts requiring maintenance (only the battery must be changed; see section “Changing the battery”).
- Only parts that comply with the original device data may be used for repairs. Electrical and mechanical parts, which are essential for providing protection against sources of danger, are located in this device.
- Liability and warranty claims are waived in the event of repairs performed by the user, improper connection of the device or incorrect operation.

Water-resistance

The GPS watch is water-resistant up to 3 bar; the chest strap is splash-proof.

Refer to the table below to determine the level of water-resistance for your GPS watch and appropriate use. The bar value refers to air overpressure that was applied to test water-resistance (DIN 8310).

Water resistant up to	Rain, splashes	Washing hands	Showering	Bathing, swimming	Water sports
n/a	Yes	No	No	No	No
3 bar ¹	Yes	Yes	No	No	No

1) The watch withstands a pressure of 3 bar for a limited amount of time.

NOTICE!

Risk of damage!

- Do not immerse the GPS watch or the transmitter in water or other liquids.
- Do not press the keys when the GPS watch is wet. Otherwise, water could penetrate the housing and damage the clockwork.
- Keep in mind that salt and thermal water may cause metal parts to corrode.
- It is recommended that you do not wear the watch in a sauna or in the shower as differences in temperature may cause condensation to form, which could damage the clockwork.

- Peak pressures may occur when swimming or when exposed to a water jet (e.g. when showering or washing your hands). During such activities, affected areas may be subjected to a significantly greater pressure than expected for the immersion depth. Only watches with a classification of 5 bar or more can be considered water-proof (showering allowed). Watches with a classification of 10 bar can also be used when swimming.
- If a watch is subjected to substantial changes in temperature such as when sun-bathing followed by a dip in cool water, liquid may condense in the housing. This is not necessarily a sign that it is not water proof; it is, however, imperative that the moisture is removed. Contact our customer service team in such cases.

Start-up

Charging the battery pack of the GPS watch

The GPS watch has an integrated lithium polymer battery pack. Fully charge the GPS watch before first use (approx. 3 hours).

1. If necessary and to avoid corrosion, dry the contact points **25** of the GPS watch thoroughly before starting the charge process.
2. Secure the clip on the USB cable **2** on the GPS watch **1** (see **fig. D**).

NOTICE!

Risk of damage!

Incorrectly connecting the cable may cause the watch or cable to heat up.

- Make sure that the USB cable is connected so that the metal pins on the clip lock directly into the contact points of the watch.

3. Connect the USB cable with a USB charger or a USB port on your computer carrying power. There is no need to install a driver for charging the battery pack. If the GPS watch has been switched off, it automatically switches on when charging.

The icon of a charging battery appears on the display panel **13** during the charging process.

If the battery pack is fully charged, the “FULL” indicator will appear.

4. Pull the USB plug out of the USB charger or PC.
5. Carefully take the clip for the USB cable off of the GPS watch.

Battery pack charging level

One battery pack charge is sufficient for max. 16 hours of operation in workout mode with GPS and approx. one year in watch mode.

The battery pack charging level is indicated with four bars in the icon **20** on the display panel **13**.

- If only one bar is visible, you should charge the watch as soon as possible.

Chest strap

The elastic chest strap with the transmitter unit is for measuring the heart rate. The transmitter unit records heart beats via the gummed area of the chest strap and transmits the pulses to the GPS watch via Bluetooth®. Therefore, you must establish a Bluetooth® connection between the GPS watch and the transmitter unit (“Pairing”) after putting on the chest strap. By factory default, the watch is paired with the chest strap. Normally, re-pairing is only required after changing the batteries of the chest strap or after changing the chest strap.

The battery is already inserted in the chest strap upon delivery; it is operational. The section “Changing the battery of the transmitter unit” explains how to change the transmitter unit’s battery.

The transmitter unit becomes active when you put the chest strap on and switches off when you take the chest strap or transmitter unit off.

To put the chest strap on:

1. To ensure proper contact with the skin, wet the gummed surface of the chest strap **7** with a small amount of warm water or apply a small amount of ECG gel (available in special medical stores) (see **fig. F**).
2. Use the snap fasteners to connect the transmitter unit **8** with the chest strap (see **fig. G**).
3. Adjust the chest strap so that it is fitted firmly on the chest under the pectoral muscles and the transmitter unit is the right way around (see **fig. H**).
4. Switch the GPS watch to workout mode and have it display your heart rate (see section “Workout mode with GPS”). The heart beat icon **17** or **22** or in the top row **15** will start flashing and your heart rate will be displayed after a short time.
If this is not the case, refer to the chapter “Troubleshooting”.

Bike holder

The GPS watch can be worn like a wristwatch or be mounted on the handlebar of your bike with the enclosed holder:

1. Mount the bike holder **4** on the handlebar of your bike.
2. Use the enclosed insertion plate **6** if the bike holder is too loose.
3. You can use cable straps **5** to permanently mount the bike holder:

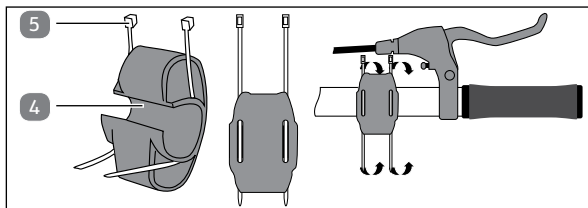
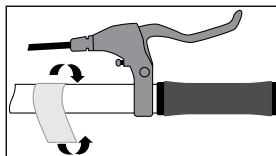

4. Mount the GPS watch on the bike holder.

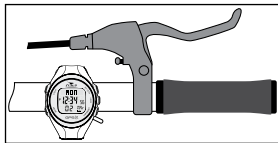

Downloading and installing the Crane Connect app

You can use the GPS watch with your smartphone (Android or iOS). For this, you will need the free **Crane Connect App**:

The app works with iPhone 4s and higher, iPads from the 3rd generation and higher, Bluetooth® Smart Ready smartphones and tablets with Android 4.3 as well as more recent versions. Bluetooth® 4.0 must be supported. You can find a compatibility list on www.cranesportsconnect.com/compatibility.

- Download the free Crane Connect app from the App Store, from the Google Play Store or via the following QR code:

QR code for Android:



QR code for iOS:



- Install the Crane Connect app on your smartphone.



NOTICE!

Follow the instructions on your smartphone for this.

General information about GPS

The global positioning system (GPS) uses a network of US satellites to measure distance, speed and altitude. The United States of America operates this network of satellites and is also responsible for its accuracy and maintenance.

Proper reception of satellite signals is only possible in clear weather (clear skies) and suitable reception area – an open area with an unobstructed view of the sky.

Poor weather (e.g. heavy snowfall) and a disrupted reception area (GPS watch is covered by clothing or other objects, high rises, narrow valleys and gullies inhibit reception) can significantly affect the performance and accuracy of the GPS watch.

GPS reception is significantly restricted in buildings: Under certain circumstances, it may be possible to determine one's position in the vicinity of windows with an unobstructed view of the sky; however, it is not possible to receive GPS signals in other indoor areas and in basements.

If the GPS watch is not able to receive a signal, it will switch GPS off after 30 minutes to save battery power.

Accuracy of GPS

The GPS watch is accurate to 3 metres CEP (50 %) outdoors. The specification of accuracy refers to so-called 50 % CEP (circular error probability).

This means that with excellent satellite reception, 50 % of all measurements are located within a circle with the specified radius of 3 m. However, this also means that half of the measurement points are outside of this radius.

But 95 % of all measurement points are located within a circle with twice the specified radius. With excellent satellite reception, nearly all points are located within a circle with a radius of 6 m.

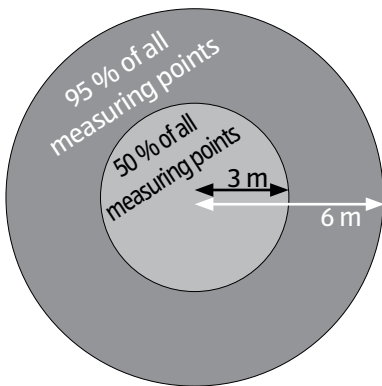

Finding satellites

In ideal conditions during a cold start, finding satellites may take up to a few minutes or only a few seconds with a warm start.

A cold start is at hand when you use the GPS watch for the first time, haven't used it for a prolonged period or have covered a considerable distance since the last time your position was determined (e.g. 300 km).

In this case, the GPS watch must retrieve the satellite constellations again.

A warm start is possible when the GPS watch has not covered a large distance since the last time the position was determined and providing a considerable amount of time has not passed. The more satellites have moved out of the periphery of the GPS watch since the last positioning, the longer it will take to find satellites.

For fast GPS reception, it is important that the watch must be in an idle position and motionless.



Tip: Before you start your workout, set your GPS watch down in open terrain with an unobstructed view of the sky (e.g. on a window ledge or car roof) and activate workout or interval mode (see sections “Workout mode” and “Interval mode”) so that the GPS watch starts looking for satellites.

The GPS icon **16** flashes while searching. As soon as enough satellites are received, the icon will be illuminated continuously.

Operation

Turning the GPS watch on and off

The watch is shipped in a deactivated state. The GPS watch will turn on when the battery pack is being charged.

Activation

Press and hold the LAP/RESET key **11** for approx. 5 seconds to activate the GPS watch. The time will appear on the display panel **13**.

Deactivation

To conserve battery power, you can switch the GPS watch off when not in use:

1. Switch to time mode (see section “Time mode”).
2. Press and hold the LAP/RESET key **11** for approx. 5 seconds.

As soon as the display panel **13** goes out, the GPS watch has switched off.

Locking keys

You can lock the key functions to protect against unwanted use:

- Tap the VIEW **10** and MODE keys **12** simultaneously.
A key icon and the message “ON” will appear briefly on the display panel.
The keys are now locked.



- To unlock them, tap the VIEW and MODE keys again simultaneously. A key icon and the message "OFF" will briefly appear on the display panel. The keys have now been unlocked.



Illumination of the display panel

- Tap the LIGHT **14** key to illuminate the display panel for approx. 3 seconds.

Night mode

It is also possible to continuously illuminate the display panel:

- Press and hold the LIGHT key **14** for approx. 3 seconds. This will activate night mode so that the display panel is continuously illuminated. If the GPS watch is not receiving a GPS signal, night mode will automatically deactivate after approx. 5 minutes.



NOTICE!

The light consumes a considerable amount of energy, which depletes the battery pack more quickly.

- Tap the LIGHT key to deactivate night mode. The display light will go out after approx. 3 seconds.

GPS watch modes

The GPS watch has the following main modes, which will be described in greater detail in the following sections.

- **System setting mode**
Configure basic settings.
- **Time mode**
Displays the current and 2nd time.
- **Workout mode with GPS**
Perform sport with automatic measurement of distance and heart frequency.
- **Interval mode with GPS**
Perform different sports one after another.
- **History mode**
Access the workout summary.
- **Alarm mode**
View and configure alarm time.

By tapping the MODE key **12**, you access the modes one after another except for the setting mode which is described below.

System setting mode

In setting mode, you define the basic settings for the GPS watch such as language, time and display panel contrast.

To access the setting mode:

1. Access the time mode:

To do so, tap the **MODE** key **12** several times until the word “CLOCK” appears on the top row **15** and the time appears a short time later.



2. Press and hold the **MODE** key **12** for approx. two seconds.

The first item in setting mode (“PAIR”) will appear.



The following keys are active in setting mode:

- **ST./STP** **9** – Increase the value, change selection (e.g. yes/no or units, etc.), start functions.
- **LAP/RESET** **11** – Reduce value, change selection.
- **VIEW** **10** – Skip to the next menu item.
- **MODE** **12** – Leave menu, back to time mode.

Any changes made to values take effect immediately.

You can make the following settings:

PAIR ? Strap

This function establishes a Bluetooth® connection between the chest strap transmitter unit and the GPS watch.

1. Put on the chest strap
(see section “Chest strap”).

2. Access the menu item
“PAIR ? Strap”.



3. Tap the ST./STP key **9**.

The message “PAIRING” will appear;
the connection will be established.

- After a short time, the message “DONE!” will appear and the Bluetooth® connection will be established.
- If the message “FAIL!” appears, check to make sure that the chest strap is properly fitted and start from the beginning.

PAIR ? APP

This function establishes a Bluetooth® connection between the GPS watch and the Crane Connect app on your smartphone (see section “Downloading and installing the Crane Connect app”).

1. Activate Bluetooth® on your smartphone.
2. Start the Crane Connect app on your smartphone.
3. In the app, select the icon for the GPS watch in the “All settings” menu.

The “Settings” menu will appear.

4. Tap the option “Connect” in the “Pairing” field.
5. On the GPS watch, access the menu item “PAIR ? APP”.



6. Tap the ST./STP key **9**.
The message “PAIRING...” will appear; the connection will be established.
- After a short time, the message “DONE!” will appear and the Bluetooth® connection will be established.
 - If the message “FAIL!” appears, make sure that Bluetooth® is activated on your smartphone and start from the beginning.

GPS SYNC

This function switches automatic syncing of the time via the GPS signal ON or OFF. The GPS system is activated in workout and interval mode. A very accurate time signal automatically adapted to your current time zone is transmitted at the same time.



Summer time (DST)

As soon as you have activated the “GPS Sync” function, summer time is switched ON or OFF as a result.



Setting the time (SECOND)

If you have deactivated the “GPS Sync” function, manually set the time by following the steps below:

The time will appear on the display panel and the word “SECOND” will appear on the top row **15**. The seconds indicator will flash.



1. To reset the seconds to zero, tap the ST./STP key **9**.
Then wait e.g. for the time signal from a radio station.
2. Tap the VIEW key **10**.
The word “MINUTE” will appear on the top row and the minute indicator will flash.
3. Use the ST./STP **9** and LAP/RESET **11** keys to set the minutes.
4. Repeat steps 2 and 3 to set the hours, year, month and day.

Time format (FORMAT)

You can switch the time displayed between 12 hours (“AM/PM”) or 24 hours.

- Tap the ST./STP key **9** to switch the time format.



2nd Time (T2)

This function sets the number of hours the 2nd time should differ from the current time.

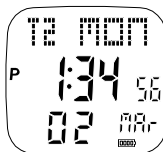

UNITS

This function determines the units of measure in which values will be displayed:



- **MET** – metric in metres (m, km, km/h) and grams (kg).
- **IMP** – imperial with foot (ft), miles (m, m/h) and British pound (lb).
- **NAU** – nautical with sea miles (nm), knots (kt) and British pounds (lb).

Automatic lap (AUTO LAP)

In workout mode, the laps covered can be counted and recorded in lap times. Mark the beginning of each lap by tapping the LAP/RESET key **11**.

With the “AUTO LAP” function, laps can automatically be generated according to the distance covered.



1. Set the desired distance after which a new lap will be marked (e.g. 1 km).
Possible values: 0.1 to 5.0 km/m/nm.
2. Tap the VIEW key **10**.

3. Set to "ON" to activate the "AUTO LAP" function.

When "AUTO LAP" is activated, you can still manually record additional lap times at any time with the LAP/RESET key **11**.

Automatic indicator change (SCROLL)

In workout mode, you can switch the values displayed with the VIEW key **10**. The function "SCROLL" will automatically change the indicator every 5 seconds. Here you can switch the automatic indicator change function ON or OFF.



HR ZONE

You can set the upper and lower heart rate limit at which the GPS watch emits a warning tone when exceeded or fallen below.



1. Set the upper limit in the centre row.
2. Tap the VIEW key **10**.
3. Set the lower limit in the bottom row.
4. Tap the VIEW key **10**.
5. Switch the warning tone ON or OFF in the bottom row.

Gender (GENDER)

Set your gender here: "M" for male, "F" for female.

This value and the weight are needed to calculate the calories burned.

WEIGHT

Set your weight here.

KEY TONE

You can activate key sounds and acoustic signals when changing activities in interval mode (“ON”) or you can deactivate them (“OFF”).

CONTRAST

You can set the LCD contrast from 1 (bright) to 16 (dark) to optimise the readability of the display panel for you.



Language (ENGLISH)

Here you can configure the language to be displayed on the display panel. Possible selections: “DEUTSCH” and “ENGLISH”.

RESET

During a reset, all values are reset to the basic settings and all data (workout history etc.) are deleted.

- Select “YES” to perform a reset.
- Select “NO” if you do not want to perform the reset.

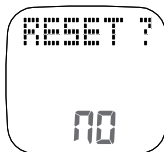

Time mode

In time mode, you see the current time and date. The GPS function is deactivated in order to save power; a battery pack charge lasts for approx. one year.



To access the time mode:

- If necessary, tap the MODE key **12** several times until the word “CLOCK” appears in the top row **15** and the time appears a short time later.
- Press the VIEW key **10** to switch between the current time and the 2nd time.

Workout mode with GPS

In workout mode, you can perform a sport and the GPS watch will automatically measure the distance and heart rate. From this data and the values you provided for gender and weight, the GPS watch will also determine the calories burned.

After your workout, the GPS watch will save all relevant data and you can view this data on your GPS watch or transfer it to the Crane Connect app on your smartphone/tablet for further analysis. If the Internet connection on your smartphone is active, the Crane Connect app will automatically upload all workout data to the website www.cranesportsconnect.com for permanent storage after your workout.

The preprogrammed sports “Running”, “Cycling” and “Hiking” as well as profiles 1 and 2 differ with respect to the values displayed: Whilst cycling, speed is of interest and while hiking, altitude.

To access the workout mode:

- If applicable, tap the MODE key **12** several times, until the name of one of the preprogrammed sports mentioned above appears on the top row **15**.

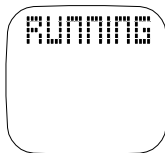

The GPS watch will look for the GPS signal and the GPS icon **16** will flash. Once a GPS signal is received, the icon will be illuminated continuously.

After a moment, the preset indicators for this sport will appear. A total of 6 values can be displayed on 2 pages.



- With the VIEW key **10**, you can switch the indicator between the 1st and 2nd page.

Selecting a sport

Before you start the workout, you can select another sport:

- Press and hold the LAP/RESET key **11** to select a preprogrammed sport. The 5 predefined sports will appear one after another in the top row **15**: RUNNING, CYCLING, HIKING, USER 1, USER 2.
- Once the desired sport is displayed, release the LAP/RESET key.

The following table will show you the preprogrammed indicators:

Sport	Indicator 1st page	Indicator 2nd page
RUNNING	duration, distance, pace	lap time, heart rate, calories
CYCLING	speed, distance, duration	average speed, heart rate, calories
HIKING	height, distance, duration	time, heart rate, calories
USER 1	distance, pace, duration	lap time, heart rate, lap number
USER 2	heart rate, duration, height	geographic lati- tude, distance, geographic longitude

Configuring an indicator

You can modify the values to be shown:

- **Top row** **15**: press and hold the LIGHT key **14**.
- **Centre row** **18**: press and hold the VIEW key **10**.
- **Bottom row** **19**: press and hold the MODE key **12**.

The following values can be shown in the centre line:

- Distance (0-99.99)
- Duration (format up to 60 minutes = mm:ss.th, 1 hour and over = hh:mm:ss)
- Current heart rate
- Current pace ("CP")
- Current speed ("km/h"/"MPH"/"kn")

The following values can be displayed in the top and bottom row:

- Altitude (0-9999m)
- Calories (0-9000)
- Distance (0-99.99)
- Duration (format up to 60 minutes = mm:ss.th, 1 hour and over = hh:mm:ss)
- Current heart rate
- Lap No. (0-99)
- Lap time (format up to 60 minutes = mm:ss.th, 1 hour and over = hh:mm:ss)
- Average pace ("AP")
- Current pace ("CP")
- Average speed ("AS")
- Current speed ("km/h"/"MPH"/"kn")
- Time
- Geographic latitude (degree of latitude, LAT)
- Geographic longitude (degree of longitude, LON)

Starting/stopping the workout

- Before starting your workout, wait until the GPS watch is receiving a proper GPS signal and the GPS icon **16** is no longer flashing (also see section “Finding satellites”).
- Press the ST./STP key **9** to start or stop the workout.
The workout icon **24** will illuminate.
It will go out when you stop your workout.

Taking lap times

- During your workout, press the LAP/RESET key **11** to take a lap time.
The laps can also be timed automatically (see section “AUTO LAP”).
A maximum of 99 lap times are saved for each workout.

After your workout

Once you have completed your workout, transfer the training data to the memory of the GPS watch:

- Press and hold the LAP/RESET key **11** until the message “SAVED!” appears in the top row **15**.

As a result, you have reset all data for the workout to zero and can start a new workout. The data for the workout you completed will be stored in the memory of the GPS watch. You can view them in the history later (see section “History mode”) or transfer them to the Crane Connect app on your smartphone/tablet (see section “Data transfer”).

- Complete your workout (the workout symbol **24** will go out) and finish by accessing time mode. Thus, you terminate GPS reception to save battery power of the GPS watch.

Interval mode with GPS

In interval mode, you can perform up to four sports consecutively and with multiple repetitions.

Example: You configure three repetitions, the first activity involves 5:00 minutes of running, the second activity involves 3:00 minutes of walking. You start your workout, the GPS watch displays “RUN” and counts down from 5 minutes. A time signal will sound when ten seconds are left; then the 2nd activity will begin. The GPS watch displays “WALK” and counts down from 3 minutes; a time signal will be emitted when 10 seconds are left. Then the first activity will restart. The process will be repeated a second time, then the workout is complete and “FINISHED!” will appear on the GPS watch.

As in workout mode, the GPS watch automatically measures the distance and heart rate and calculates the calories burned. After your workout, the GPS watch will save all relevant data and you can view this data on your GPS watch or transfer it to the Crane Connect app on your smartphone/tablet for further analysis. If the Internet connection on your smartphone is active, the Crane Connect app will automatically upload all workout data to the website www.cranesportsconnect.com for permanent storage after your workout.

To access the interval mode:

- Tap the MODE key **12** several times if necessary until the word “INTERVAL” appears in the top row **15**.

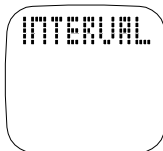

After a moment, the first activity (in this case “Run”) with the configured time (in this case 3 minutes – “03:00”) will appear and the number of repetitions (“03 REP”).



Defining intervals

Before you start your workout, you can define how it is structured:

1. In interval mode, press and hold the MODE key **12** until the number of repetitions flashes in the bottom row.

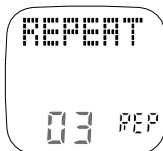

2. Configure how often certain activities will be repeated.

3. Tap the VIEW key **10**.
The first activity will be shown.

4. Select “OFF” to deactivate this activity and continue with step 11.
Or select “ON” to edit the sport.



5. Tap the VIEW key **10**.
The sport will start to flash.

6. Now select one of the following sports:

RUN, JOG, WALK, REST, FAST, MED, SLOW.

7. Tap the VIEW key **10**.
The workout duration will start to flash.
 8. Set the minutes for the desired workout length.
 9. Tap the VIEW key **10**.
 10. Set the seconds for the workout length.
 11. Tap the VIEW key **10**.
 12. Repeat steps 4 to 11 for the other three sports.
- You have now defined your interval workout.

Starting/stopping the interval workout

- Before starting your workout, wait until the GPS watch is receiving a proper GPS signal and the GPS icon **16** is no longer flashing (also see section “Finding satellites”).
- Press the ST./STP key **9** to start or stop the interval workout.
The workout icon **24** will illuminate. It will go out when you stop your workout.
- To switch to the next sport before the set time has elapsed, tap the LAP/RESET key **11**.

After your workout

Once you have completed the workout, the GPS watch will automatically save the workout data.

If you stop the workout early with the ST./STP key **9**, you can manually save the workout data to the memory of the GPS watch:

- Press and hold the LAP/RESET key **11** until the workout data are reset to the initial values.

As a result, you have reset all data for the workout to zero and can start a new workout. The data for the workout you completed will be stored in the memory of the GPS watch. You can view them in the history later (see section “History mode”) or transfer them to the Crane Connect app on your smartphone/tablet (see section “Data transfer”).

- Complete your workout (the workout symbol **24** will go out) and finish by accessing time mode. Thus, you terminate GPS reception to save battery power of the GPS watch.

History mode

In history mode, you can view the data saved during the workouts.

To access the history mode:

- Tap the MODE key **12** several times if necessary until the word “HISTORY” appears in the top row **15**.

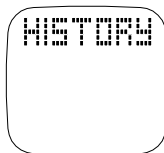

The last data record saved will appear after a moment:

- You will see the number of the data record (“02”) and the date (“APR30”) in the top row **15**.



- You will see the time when the workout is completed in the centre row.
- In the bottom row, you will see the number of laps (“L02”) to the extent they were counted and the week day (“TUE”).
- By pressing the ST./STP **9** or LAP/RESET key **11**, you browse forward or backward through the stored data records.
- By pressing the VIEW key **10**, you can access further details for the selected workouts on four or five pages. In the process, the top row will always show the number of the data record and the date.
- 2nd page
Centre: Distance, bottom: Time
- 3rd page
Centre: average speed, bottom: calories.
- 4th page
Centre: average pace, bottom: calories.
- 5th page
Centre: maximum heart rate, bottom: average heart rate.
- 6th page (only when laps were recorded)
Top: lap number and lap distance.
Centre: lap time
Bottom: split time
- In the lap view, you browse forward or backward through the stored lap data with the ST./STP **9** or LAP/RESET key **11**.
- Press the VIEW key **10** to go back to the workout

summary.

Deleting workout data

You can delete the data for the last workout or all data out of the memory of the GPS watch:

1. Access the history mode (see previous section).
2. Press and hold the MODE key **12** until the word “DELETE” appears in the top row.
“Last” will appear in the centre row.
3. If you do **not** want to delete the last workout you saved, proceed with step 6.
4. If you would like to delete the last workout saved, select “YES” with the ST./STP key **9** in the bottom row.
5. Tap the VIEW key **10**.
The last workout is deleted and the message “DONE !” will appear briefly. Then the GPS watch will switch back to history mode.
6. Tap the VIEW key **10**.
Now “ALL” is displayed in the centre row.
7. If you would like to delete all the workout data saved, use the ST./STP key **9** to select “YES” in the bottom row.
8. Tap the VIEW key **10**.
If you selected “Yes” in the previous step, all data records have been deleted and the message “DONE !” will appear briefly. Then the GPS watch will switch back to history mode.

Alarm mode

In alarm mode, you can view and set the alarm time.

To access the alarm mode:

- If necessary, tap the MODE key **12** several times until the word “ALARM” appears in the top row **15**.
The set alarm time will appear after a moment.
- You can switch the alarm ON or OFF in the bottom row with the ST./STP key **9**.

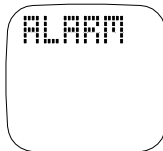

Setting the alarm time

1. Press and hold the MODE key **12** in alarm mode until the number of hours flashes in the centre row.
2. Set the hour for the intended alarm time with the ST./STP **9** and LAP/RESET key **11**.
3. Tap the VIEW key **10**.
The number of minutes will flash in the centre row.
4. Use the ST./STP **9** and LAP/RESET key **11** to set the minutes for the intended alarm time.
5. Tap the VIEW key **10**.
The alarm has now been set and switched ON.

An alarm signal will sound for 30 seconds at the set alarm time which you can switch off by pressing any key. The settings will remain intact and the alarm will “ring” again the next day.

Data transfer

In order to transfer the workout data saved on the GPS watch to the Crane Connect app on your smartphone/tablet, the following prerequisites must be in place:

- End any workouts in progress (the workout symbol  must be off).
- Save the last workout data on the GPS watch (see both sections “After your workout”).
- Access the time mode (see section “Time mode”).
- Activate Bluetooth® on your smartphone or tablet.
- Install the Crane Connect app on your smartphone/tablet.
- In the app’s home menu, open the analysis via the symbol for the GPS watch. The app will connect to the GPS watch itself and the data transfer will start.
- In the app, you can select whether the data will be automatically deleted from the GPS watch after the transfer or whether it will be retained there.

Cleaning and maintenance

NOTICE!

Risk of damage!

Water that has penetrated the housing can cause damage to the GPS watch or the transmitter unit.

- Never immerse the GPS watch or the transmitter unit in water.
- Make sure that no water penetrates the housing.

NOTICE!

Risk due to improper operation!

Improper handling of the GPS watch may result in damage.

- Do not use any aggressive cleaners, brushes with metal or nylon bristles or similar. They could damage the surfaces.
 - Make sure that no drops of water are left on the display of the GPS watch. Water may cause permanent discolouration.
1. Only clean the GPS watch and the chest strap with a soft, damp and lint-free cloth.

2. Check the charging contacts **25** on the back of the watch. If they are contaminated with perspiration residue, flakes of skin or dust, use the cleaning brush **3** contained in the product contents.
3. Add a few drops of clean water to the contact pins of the watch and then clean them with the cleaning brush.

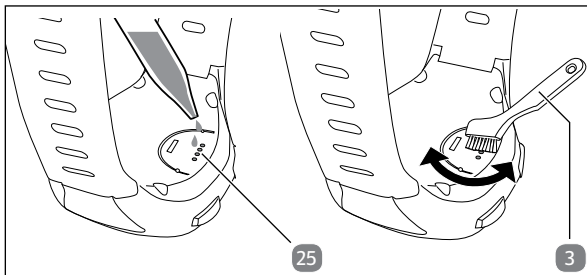

Changing the transmitter unit's battery

NOTICE!

Risk of damage!

If you do not close the battery compartment cover properly, moisture may penetrate the transmitter unit. This could lead to damage to the transmitter unit.

- Firmly close the battery compartment cover to prevent moisture from penetrating the transmitter unit.

1. To open the battery compartment cover **26**, use a coin to turn it counterclockwise.

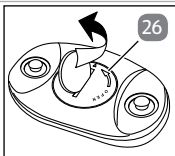

2. Take the old battery out and insert a new one of the same type so that it is in the same position. Do not remove the white sticker from the battery compartment.

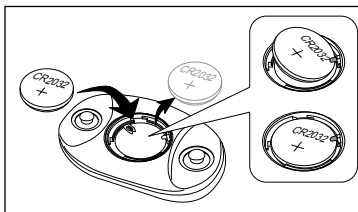

The battery must be located under the small golden metal hook, the positive pole must be pointing up.

3. Put the battery compartment cover back into place. Observe the marks on the cover and on the housing.

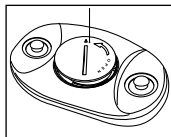

4. To close the battery compartment cover, use a coin to turn it clockwise.

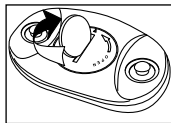

Storage

- Clean the GPS watch and the chest strap thoroughly before storage (see section “Cleaning”).
- Charge the battery pack fully.
- Switch the GPS watch off.
- Remove the battery from the transmitter unit.
- Always store the GPS watch and the chest strap in a dry place.
- Protect the GPS watch and the chest strap against exposure to direct sunlight and other sources of heat.
- Store the GPS watch and chest strap so that they are not accessible for children at a storage temperature between -20 °C and +70 °C.



Troubleshooting

Problem	Possible cause	Solutions, tips
The battery pack in the GPS watch is not charging.	The charging cable is not properly connected.	The metal pins must lock directly into the contact points of the watch.
	Charging contacts are dirty.	Clean the charging contacts on the back of the watch (see section "Cleaning").
	USB port is de-energised.	Make sure that the USB port to which the GPS watch is connected has power.
Keys don't respond.	Keys are locked.	To unlock them tap the VIEW 10 and MODE key 12 at the same time.

Problem	Possible cause	Solutions, tips
Display blank.	The GPS watch is off.	To turn it on, press the LAP/RESET key 11 for approx. 5 seconds.
	The battery pack is empty.	Charge the battery pack.
	Contrast too low.	Increase the contrast (see “System setting mode”, “Contrast”).
Display dark.	GPS watch is overheated (exposure to sunlight, excessively high ambient temperature).	Let the GPS watch cool off.
Display very slow.	Normal at temperatures below 0 °C.	When the temperature rises above 0 °C again, the display will return to normal.

Problem	Possible cause	Solutions, tips
Speed is not shown.	GPS reception insufficient.	Observe the notes on “General information about GPS”.
Speed is shown although not walking/cycling.		
Heart rate is not shown.	Connection between the GPS watch and the chest strap interrupted.	Establish the Bluetooth® connection between the GPS watch and the chest strap (see section “Pair? Strap”).
	Transmitter unit battery empty or inserted incorrectly.	Check the battery (see “Changing the transmitter unit's battery”).
	No conductive connection with the skin because the chest strap is too dry.	Moisten the gummed part of the strap with a small amount of water.

Problem	Possible cause	Solutions, tips
Workout cannot be started. "Memory full!" message.	The memory of the GPS watch is full; the workout time or lap time exceeds 99 hours.	Transfer data to the Crane Connect app and clear memory (see section "RESET").

Memory full

Please make sure that the GPS watch does not automatically clear the memory containing your data.

To do so, you must activate automatic clearing of the memory after a data transfer under Settings before the data is transferred from the GPS watch to the app.

If the memory of the watch is full, no more data can be recorded and the time measurement for the workout can no longer be started in workout or interval mode.

This means that the ST./STP key can no longer be pressed. However, before the memory is full, the message "Memory full!" will appear on the display of the GPS watch. Once the workout time or the lap time is full (99h), no further recording is possible either!

If you have further questions, you can also reach us at the following address:

Krippel-Watches
 Freepostcode:
 RLTU-ZYZE-SKLG
 Picadilly 180
 W1J 9HF London
 UNITED KINGDOM

E-mail address: service@cranesportsconnect.com

Please visit the following website for helpful FAQs for your GPS watch.

<http://www.cranesportsconnect.com>

EAN Code: 20023898

Technical data

Model:	AE5-GPS-6A/6B/6C
Power supply	
– GPS watch	lithium polymer battery pack, 380 mAh, 3.7 V
– Transmitter unit	lithium battery 3 V, CR2032
Transmission frequency from the transmitter unit to the GPS watch:	Bluetooth® 4.0
GPS accuracy:	3 metres CEP (50 %) in the open
Operating temperature:	-10 °C to +60 °C
Storage temperature:	-20 °C to +70 °C
Article number:	92412

All data stated are merely nominal values. Technical changes reserved.

Declaration of conformity

C E Krippel-Watches hereby declares that the GPS watch (model no. AE5-GPS-6A/6B/6C) complies with the fundamental requirements and other applicable provisions of the R&TTE 1999/5/CE, 2004/108/EC (electromagnetic compatibility) and RoHS 2011/65/EU directives.

You can access the complete text for the declaration of conformity on our website:

www.produktservice.info (EAN code: 20023898).

Disposal

Disposing of the packaging



Dispose of the packaging separated into single type materials. Dispose of cardboard and carton as waste paper and foils via the recyclable material collection service.

Disposing of old devices

(Applicable in the European Union and other European states with systems for the separate collection of reusable waste materials)



Old devices must not be disposed of with household waste!

If the GPS watch can no longer be used, every user is required **by law to dispose of old**

devices separately from their household waste, e.g. at a collection point in his community/borough. This ensures that old devices are recycled in a professional manner and also rules out negative consequences for the environment. For this reason, electrical equipment is marked with the symbol shown here.

Batteries and rechargeable batteries may not be disposed of with household waste!



As the end user you are required by law to bring all batteries and rechargeable batteries, regardless whether they contain harmful substances* or not, to a collection point run by the communal authority or borough or to a retailer, so that they can be disposed of in an environmentally friendly manner.

Bring the entire GPS watch (including the battery pack) to your collection point and make sure that it is in an uncharged state!

* labelled with: Cd = cadmium, Hg = mercury, Pb = lead

IRE

GB



Warranty Card

BLUETOOTH® GPS WATCH WITH HEART RATE MEASUREMENT

Your details:

Name _____

Address _____



E-mail _____

Date of purchase * _____

* We recommend you keep the receipt with this warranty card.

Location of purchase _____

Description of malfunction:



Return your completed warranty card together with the faulty product to:

Krippel-Watches

Freepostcode:
RLTU-ZYZE-SKLG

Picadilly 180

W1J 9HF London

UNITED KINGDOM

AFTER SALES SUPPORT



GB
IRE 00800/52323000



service@cranesportsconnect.com

Model: AE5-GPS-6A/6B/6C

Product Code: 92412

06/2015

Please note: The helpline Number is a Freephone Number however please allow time (up to 10 seconds) for the international connection to take place.
(Operating Hours: Mon-Fri: 07.00 AM to 07.00 PM)

3

YEARS
WARRANTY



Warranty conditions

Dear Customer,

The ALDI warranty offers you extensive benefits:

Warranty period: 3 years from date of purchase.

6 months for wear parts and consumables under normal and proper conditions of use (e.g. rechargeable batteries).

Costs: Free repair/exchange or refund.
No transport costs.

Hotline: Free hotline.

ADVICE: Please contact our service hotline by phone, e-mail or fax before sending in the device. This allows us to provide support in the event of possible operator errors.

In order to make a claim under the warranty, please send us:

- together with the faulty item the original receipt and the warranty card properly completed.
- the faulty product with all components included in the packaging.

The warranty does not cover damage caused by:

-
- **Accident or unanticipated events** (e.g. lightning, water, fire).
 - **Improper use or transport.**
 - **Disregard of the safety and maintenance instructions.**
 - Other **improper treatment or modification.**

After the expiry of the warranty period, you still have the possibility to have your product repaired at your own expense. If the repair or the estimate of costs is not free of charge you will be informed accordingly in advance.

This does not affect your statutory rights. In the event that a product is received for repair, neither the service company nor the seller will assume any liability for data or settings possibly stored on the product by the customer.



Spend a little Live a lot.

Great care has gone into the manufacture of this product and it should therefore provide you with years of good service when used properly. In the event of product failure within its intended use over the course of the first 3 years after date of purchase, we will remedy the problem as quickly as possible once it has been brought to our attention. In the unlikely event of such an occurrence, or if you require any information about the product, please contact us via our helpline support services, details of which are to be found both in this manual and on the product itself.

PRODUCED IN CHINA FOR:

ALDI STORES LTD. PO BOX 26, ATHERSTONE
WARWICKSHIRE, CV9 2SH

ALDI STORES (IRELAND) LTD.
PO BOX 726, NAAS, CO. KILDARE.
visit us at www.aldi.com

GB

IRE

AFTER SALES SUPPORT



00800/52323000



service@cranesportsconnect.com

Model: **AE5-GPS-6A/6B/6C** Product code: **92412**
06/2015

3

**YEARS
WARRANTY**